

Microcontroller

Responsible for controlling the entire system. Receives speed from an input and drives the MOSFET driver accordingly.

Uses internal analog comparator to deduce rotor position using the BEMF.

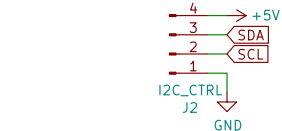

Control Connectors

Either system can be used. PWM is standard for commercial ESCs. 1 to 2ms duty, 20 ms period. It is integrated in the Serial programmer header

I added I2C in the event I want to retrieve data from the ESC or adjust speed at a rate >50Hz.

Power Pads

These connections are for the batter coming in as well as either 5V coming out of the ESC or in for the control system if BEC is not installed locally.

Test pads are just placeholders for the ends of the exposed traces. Solder wires to exposed regions.

Serial Programming

Used to upload Arduino sketches using a serial programmer.

5V Regulator Battery Eliminator Circuit

(If installed)

5V 1A Buck Regulator
Used to power ESC control system.

Can be used to power other parts of the vehicle running at 5V.

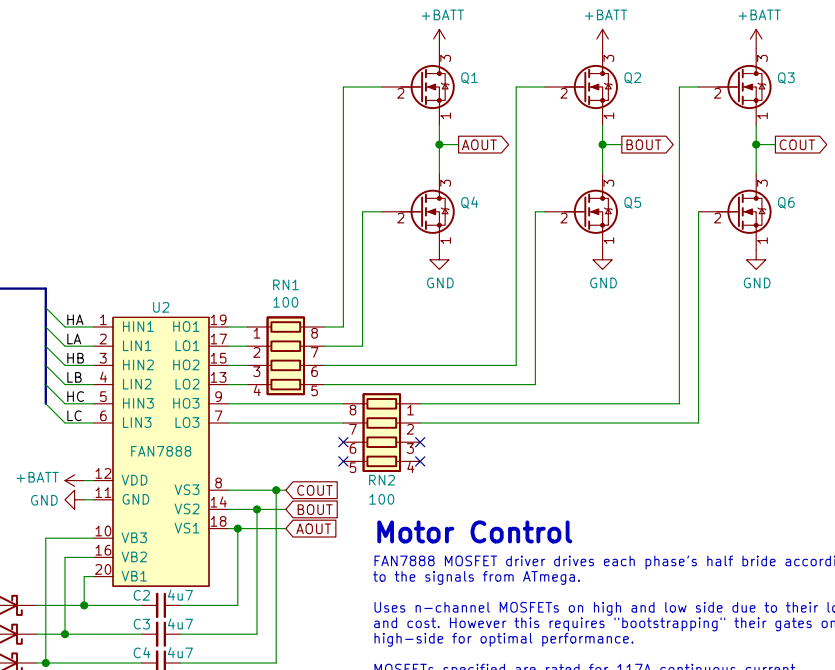
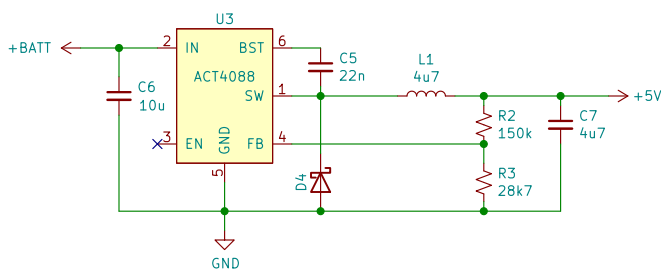

Motor Control

FAN7888 MOSFET driver drives each phase's half bridge according to the signals from ATmega.

Uses n-channel MOSFETs on high and low side due to their lower Rds and cost. However this requires "bootstrapping" their gates on the high-side for optimal performance.

MOSFETs specified are rated for 117A continuous current. However the traces are not! Add solder for safe operation.

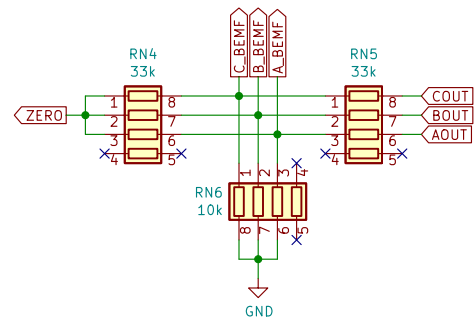

BEMF Dividers

Used to determine the position of the the rotor based on the back electromotive force (BEMF) measured in the floating phase of the motor. I won't delve into the theory here.

Resistor tolerances must be tight, so all phases have their voltage divided similarly to ensure fair comparison to the motor's "zero".

Arduino Based BEMF Electric Speed Controller for a Brushless Motor Designed for input between 10V and 20V, up to 100A System controlled by PWM or I2C Based on design from ELECTRONOBS		
Title: 20V 100A BEMF ESC		
Savo Bajic	Date: 2020-05-04	Rev: 2.1
KiCad E.D.A. kicad 6.0.1-79c1e3a40b-116-ubuntu21.04.1	Size: USLetter	Sheet: 1/1