

ASME 2020 Schematic V4 Blue Shift – HPVDT UofT

Circuit Design / PCB Layout:
Catherine Kucaba / Savo Bajic
Programming:
Ethan Baron / Yvonne Yang / Savo Bajic

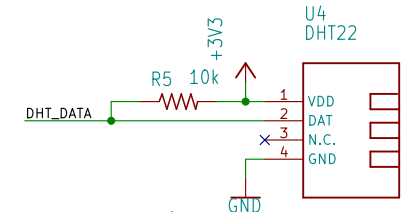

DHT22 (Digital Temp./Humidity)
Monitors the ambient temperature and humidity in proximity to the sensor. Likely mounted to the board.

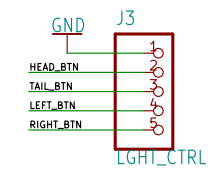

Light Control Buttons
Pulling these lines to GND will toggle the corresponding lights.

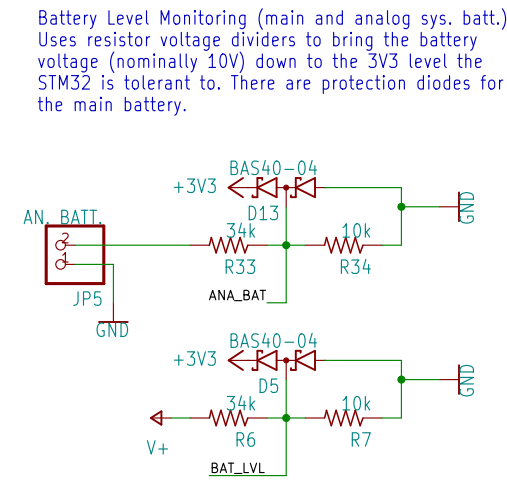

Battery Level Monitoring (main and analog sys. batt.)
Uses resistor voltage dividers to bring the battery voltage (nominally 10V) down to the 3V3 level the STM32 is tolerant to. There are protection diodes for the main battery.

Lighting Lines
Constant current boost converters. Take in the battery voltage and boost it to generate a desired current through the LEDs. Current set by resistors downstream of LEDs, $I = 0.2/R$. The 0.2 can be tweaked using the potentiometer and solder the jumper. Solder to ground to decrease the 0.2, +V to raise the 0.2. Dimming is achieved though software by applying an approximately 1kHz PWM signal to the control pin.

Raspberry Pi (RPI)
Connected to the digital camera and display to provide a view out of the vehicle. This view is overlaid with the data from the sensors. Communicates with the system over USART (serial), with protection. SHDN button pulls down a pin to signal the RPI to shutdown properly.

Data Connections
A slight mess. STM32 sits in the middle to connect everything, collect data, and handle real-time events. Protection diodes installed to shield subsystems systems in the event of any over/underloads on data lines.

Rotational Speed Encoders
Used to determine the rotational speed of either the pedals (cadence) or wheel (encoder), using a digital interrupt to change pins on the STM32. Both inputs used on the STM32 are 5V tolerant

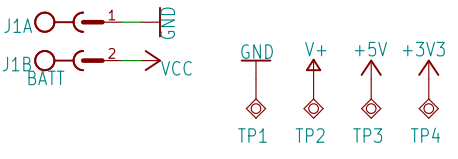
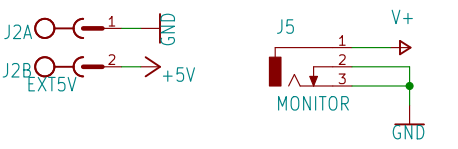
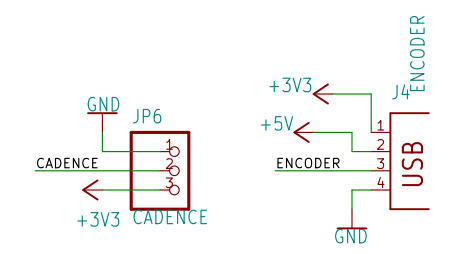

Power connections and test points
- One connector to the battery.
- Another to pass power to the monitor used.
- One connector for an external 5V supply if the built in one is non-functional or 5V is needed externally.
Test points are for the power buses.

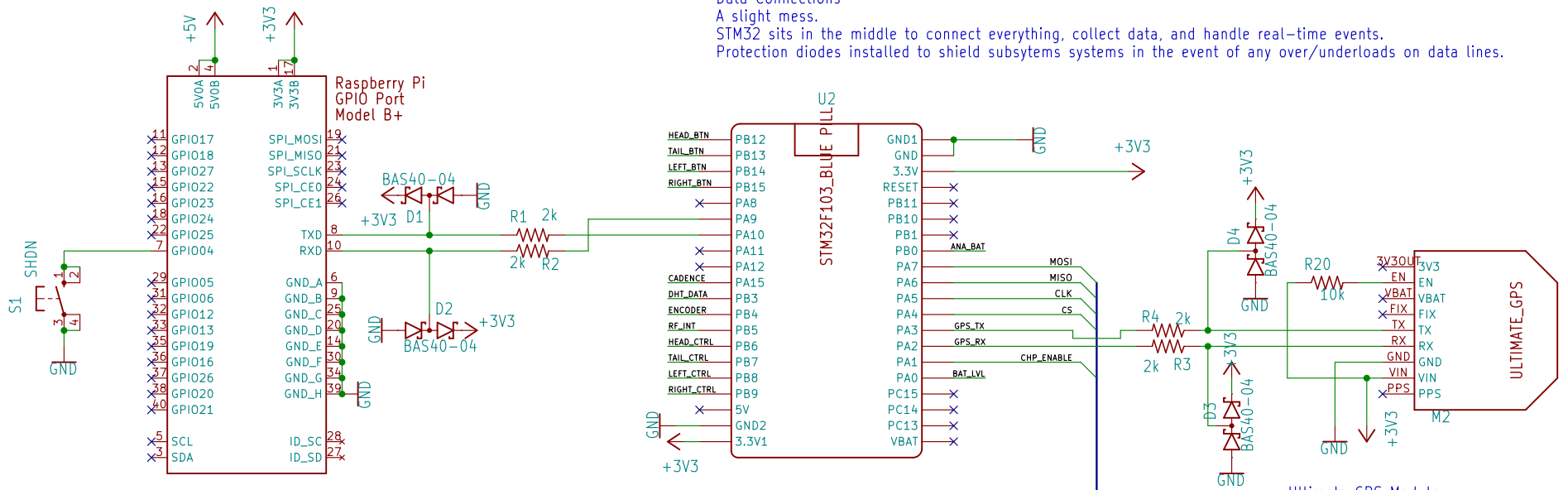

STM32F103C8 "Bluepill" Development Board (U2)
The heart of the data system for the vehicle. Collects data across pins from sensors and routes communication between the different modules as needed. Operates in a "call and response" manner, where a connected device needs to make a request for data otherwise the STM32 will not provide any information. This board operates at 3V3, although some pins are 5V tolerant.
STM32 connections:
RPI - Serial1
GPS - Serial2
nRF24 - SPI (chip select on PA4, operating mode on PA1, interrupt pulls down PB5)
Analog In - Battery levels (after resistor voltage divider)
Digital I/O for everything else (PWM for light control)

Ultimate GPS Module
Used to gather GPS data, including speed as a backup for the encoder.

nRF24L01-PA Module
Used for potential telecommunication to pit or chase vehicle. Functional range proven to be up to 1.1km.

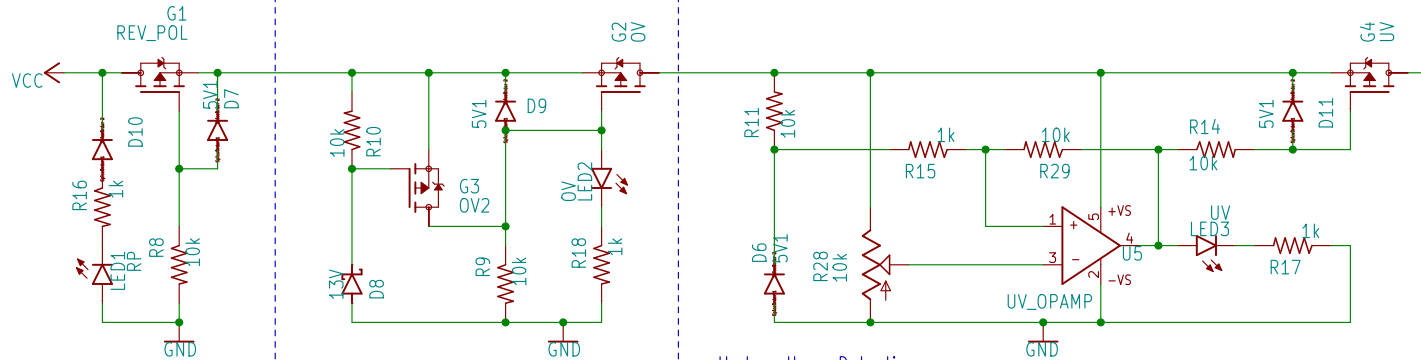
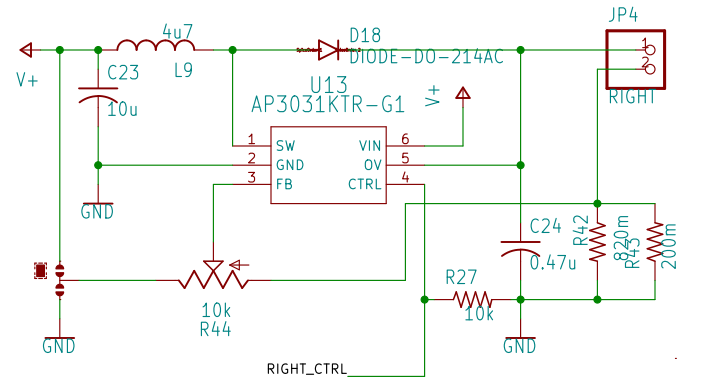
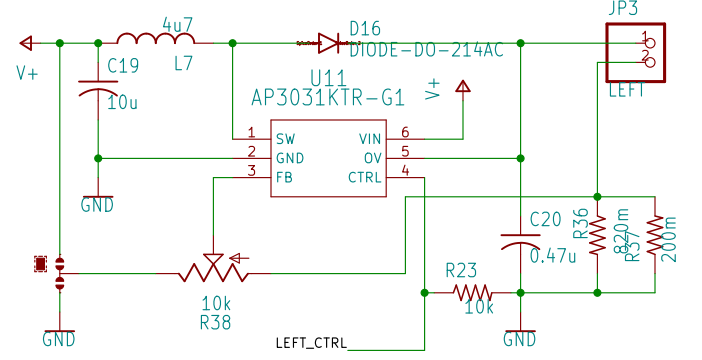
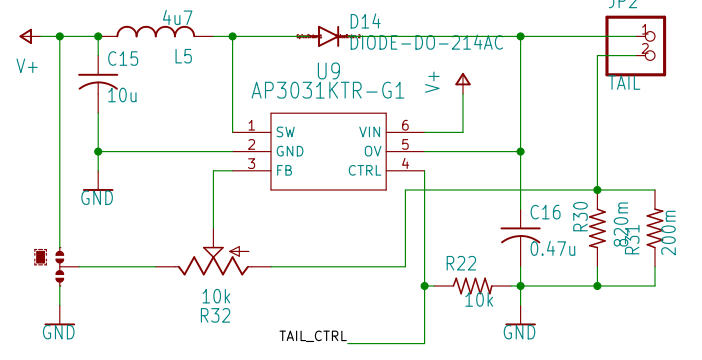
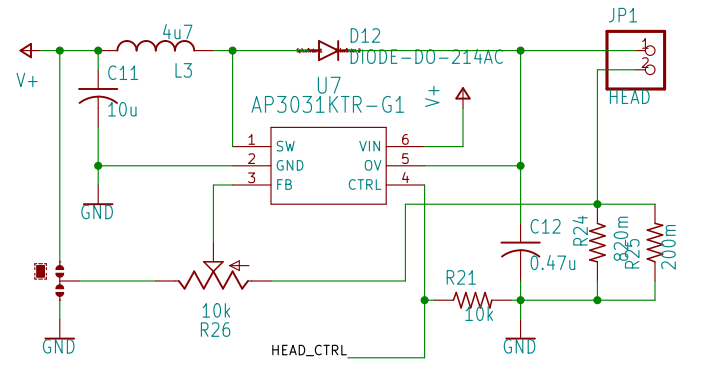

Reverse Polarity Protection
First stage of protection from the battery

Over Voltage Protection
Kicks in based around value of D8 (Currently 13V)

Undervoltage Detection
Used to prevent draining batteries too far and causing cell damage. Cutoff threshold determined by the potentiometer. Hysteresis to prevent oscillating.

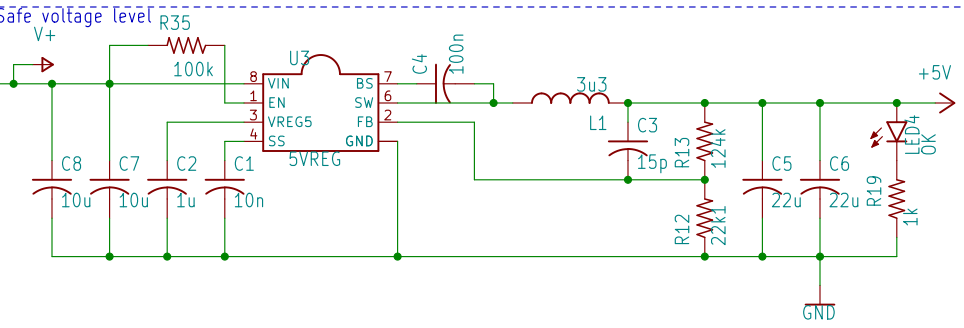

5V/4A Buck Converter
Supplies power to RPI, the 3V3 comes from RPI's regulators to the system. Uses AP65450SP-13 chip and the 5V reference design in the datasheet. If there is any power fault leading up to this an appropriate LED will indicate it, otherwise the OK will light.