

Programming

Digits are set by a set of jumpers pulling the programming pin for each bit high or low. Then pressing the load button for the target digit.

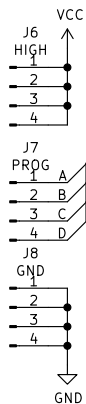

PRIMARY (LEFT) DIGIT

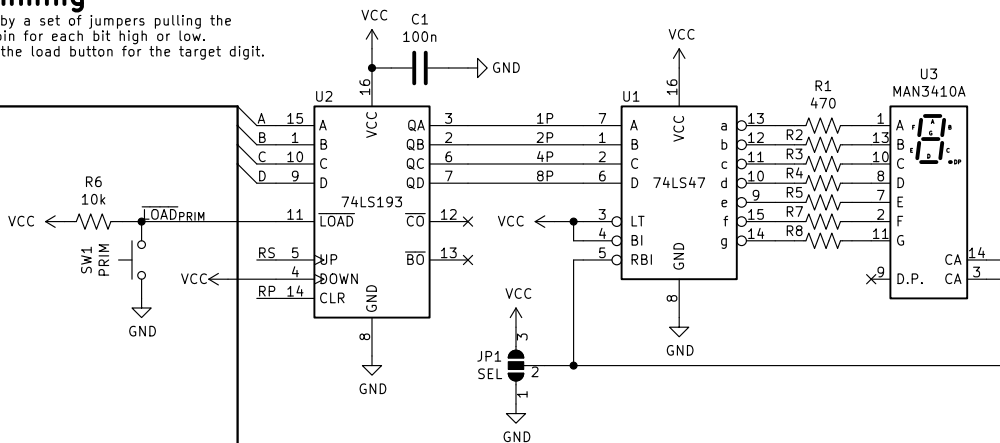

SECONDARY (RIGHT) DIGIT

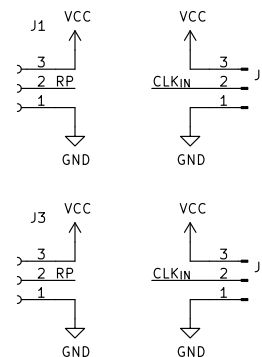
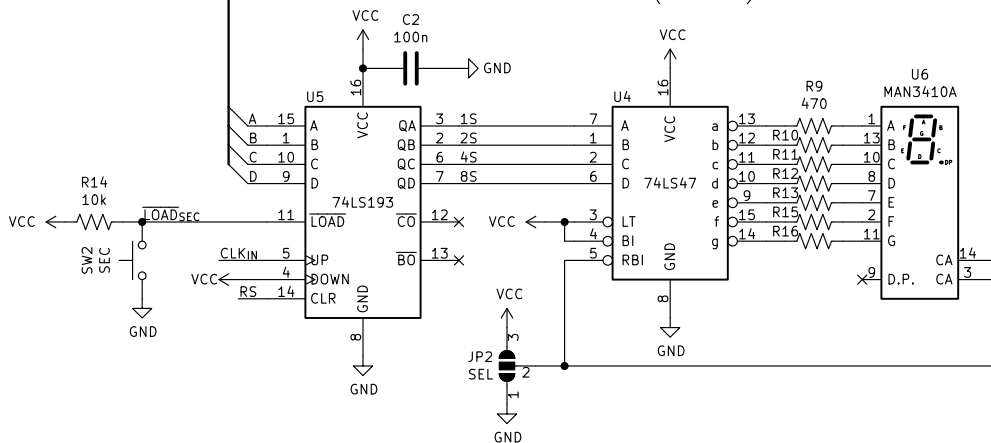

Cascading Connectors

Pass power between modules and route the carry of the previous digit to the secondary and the reset (carry) of the primary forwards.

Reset Logic

Reset signals for each digit are generated using off board logic based on the current value of each counter.

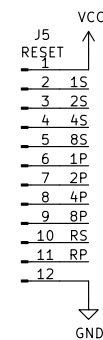

Functional Principles

74LS193 count the input pulses and output a four (4) bit value to the display drivers which then show the value on the seven-segment displays.

The counters need to be configured to reset manually using the reset signal since they loop around at 16, not at the values we're interested in (3, 5, 6, 10). This is done using the reset pins manually based on logic off board. These reset signals double as the signal for the next digit since they are essentially "carry out" signals.

Display Types

The board can be used to drive common anode displays as shown on this schematic. However by swapping out U1 and U4 (74LS47s) for CD4511s, common cathode displays can also be used since their pins line up. The only additional operation is to set the solder jumper correctly for each digit. Connecting it between 3 and 2 ("high") for CA, 1 and 2 ("low") for CC.

Hardware only clock display module
 Recives signal and power via J2/J4 and outputs to J1/J3
 Can be used with CC displays by swapping U1/4 for CD4511s

Title: Clock Display Board

Savo Bajic	Date: 2022-03-25	Rev: 1.1
KiCad E.D.A. kicad 6.0.1-79c1e3a40b-116-ubuntu21.04.1	Size: USLetter	Sheet: 1/1