

Battery moved to board

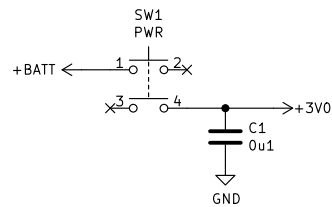

The ultimate power saving technique, completely disconnecting power when not in use.

Key ring hole

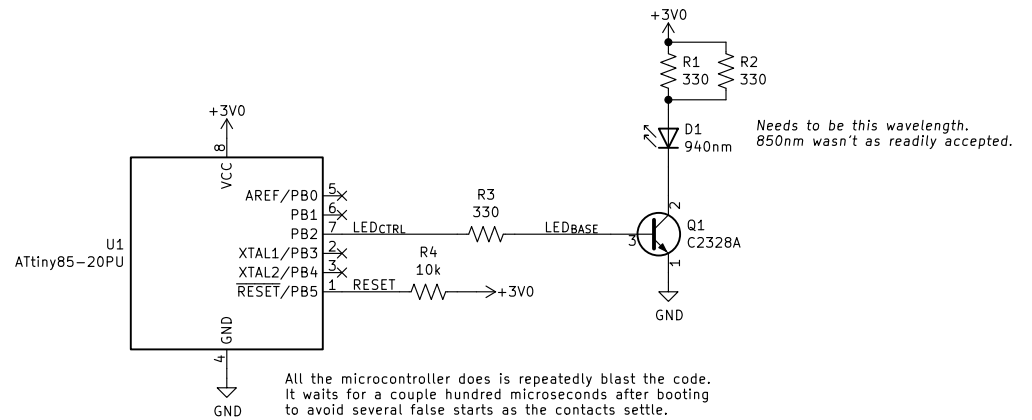

All the microcontroller does is repeatedly blast the code. It waits for a couple hundred microseconds after booting to avoid several false starts as the contacts settle.

Entry fob for a previous building I lived in  
 A redo of my previous design which used a dangling 9V battery  
 Fixed the switch connections  
 More compact and discrete overall, but decreased range

**Title: Entry Fob**

<b>Savo Bajic</b>	Date: 2022-02-15	<b>Rev: 2.1</b>
KiCad E.D.A. kicad 6.0.1-79c1e3a40b-116-ubuntu21.04.1	Size: USLetter	Sheet: 1/1