

Pulling a limit pin to GND stops the machine
Limit switches are to be wired in series, normally closed (NC)

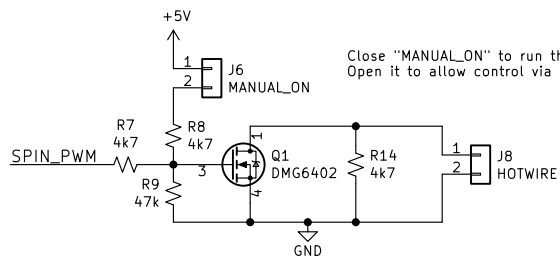

Close "MANUAL_ON" to run the hotwire on perpetually.
 Open it to allow control via "SPINDLE_PWM".

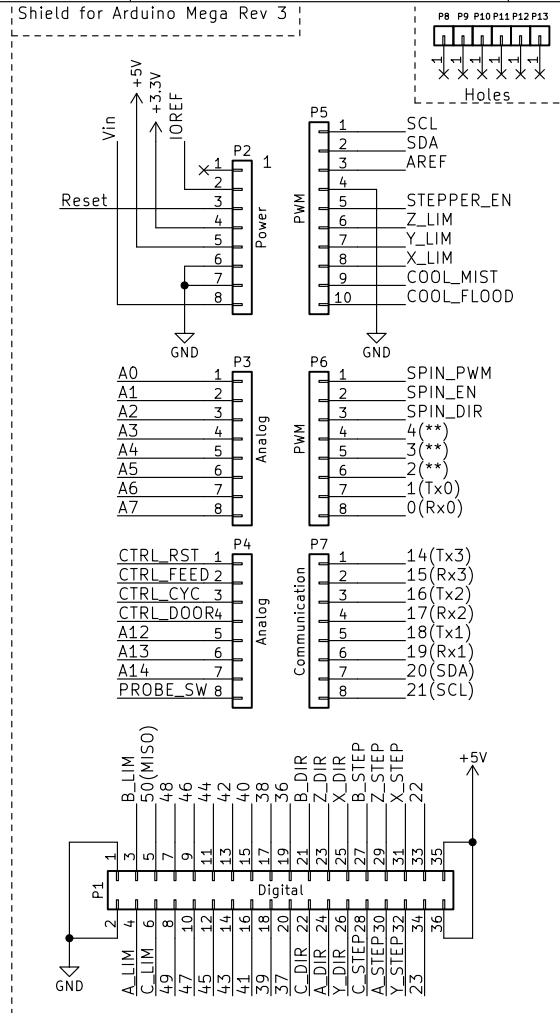
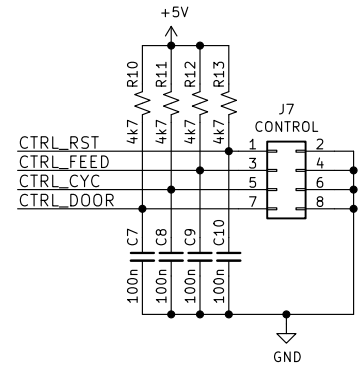

Arduino Mega based CNC controller

Pin out is default for the following project
<https://github.com/dguerizec/grbl-Mega-4axis>

Title: Hot Wire CNC Break Out

HPVDT	Date: 2021-01-01	Rev:
KiCad E.D.A. kicad 6.0.1-79c1e3a40b-116-ubuntu21.04.1	Size: USLetter	Sheet: 1/1