

Connector to Display

All the signals (and power) is exchanged via this connector to the display boards

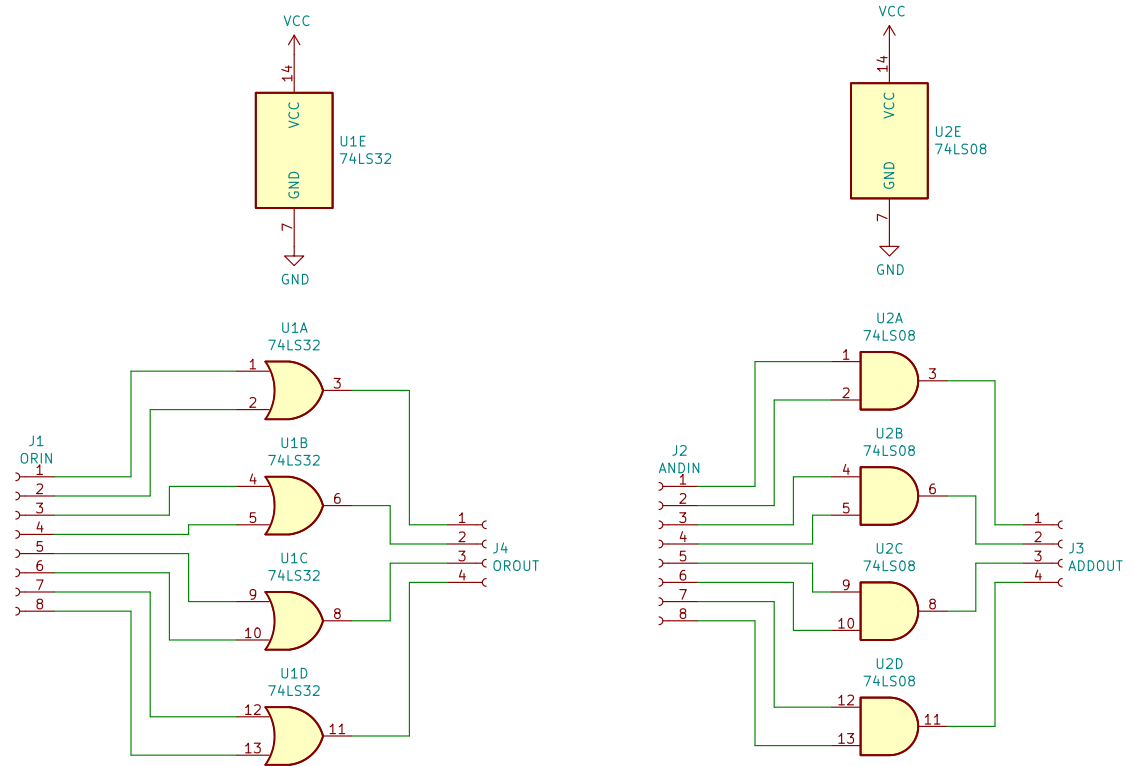

Logic Gates

The signals between logic gates and the the main connector must be done by hand by the user using jumper wires between the pads for each respective signal.

NOTE: TWO SEPERATE SIGNALS SHOULD NEVER BE SHORTED TOGETHER TO AVOID DAMAGE IF THEY TRY TO DRIVE THE SHARED CONNECTION DIFFERENT WAYS!

User configured logic for resetting counters
Configured using wires soldered between headers

Title: Clock Reset Logic

Savo Bajic	Date: 2021-11-28	Rev: 1
KiCad E.D.A. kicad 6.0.1-79c1e3a40b-116-ubuntu21.04.1	Size: USLetter	Sheet: 1/1