

## Power Delivery

Power for the whole clock is delivered here by a mini-USB. C5 and C6 act as smoothing capacitors for the 5V line. C3 and C4 are decoupling for U1 and U2 to ensure stable clock.

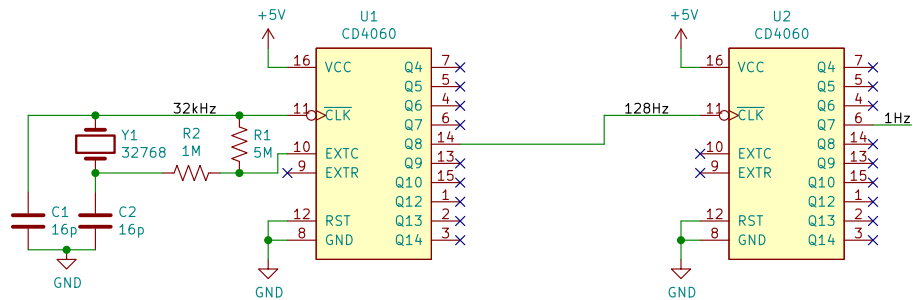

## Clock Source

A 32 768 Hz crystal is used to provide a stable base signal which is divided by 256 and then once again by 128 to output a stable, accurate 1 Hz for the clock.

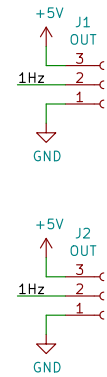

## Connectors

Proved power and the 1 Hz signal to the rest of the clock.

Accepts power via USB and produces 1Hz for the clock system

**Title: Clock Signal + Power Module**

Savo Bajic

Date: 2021-11-28

Rev: 1

KiCad E.D.A. kicad 6.0.1-79c1e3a40b-116-ubuntu21.04.1

Size: USLetter

Sheet: 1/1